

Features

- Input / Output Impedance: 1000Ω ~ 2000Ω
- Highly Selective Ceramic Filters
- Center frequency: 450kHz, 455kHz
- RoHS Compliant
- Insertion Loss (dB) max: 4 db, 6 db
- Pass Band Ripple (dB) max: 2 db
- Applications: *Radio Communication etc*



Standard Specifications (455KHz)

Part Number	Center Frequency (KHz)	Insertion Loss (dB) Max.	Passband Ripple (dB) Max.	6dB Band Width (KHz) Min.	50dB Band Width (KHz) Min.	Stop Band Att. ±100KHz (dB) Min.	Input /Output Impedance (Ω)
LT455BW	455±2.0	4	2	±15	±30	40	1500
LT455CW	455±2.0	4	2	±12.5	±24	40	1500
LT455DW	455±1.5	4	2	±10	±20	40	1500
LT455EW	455±1.5	6	2	±7.5	±15	40	1500
LT455FW	455±1.5	6	2	±6	±12.5	40	2000
LT455GW	455±1.5	6	2	±4.5	±10	40	2000
LT455HW	455±1.0	6	2	±3	±9	40	2000
LT455IW	455±1.0	6	2	±2	±7.5	40	2000
LT455HTW	455±1.0	6	2	±3	±9	60	2000

Standard Specifications (450KHz)

Part Number	Center Frequency (KHz)	Insertion Loss (dB) Max.	Passband Ripple (dB) Max.	6dB Band Width (KHz) Min.	50dB Band Width (KHz) Min.	Stop Band Att. ±100KHz (dB) Min.	Input /Output Impedance (Ω)
LT450BW	450±2.0	4	2	±15	±30	40	1500
LT450CW	450±2.0	4	2	±12.5	±24	40	1500
LT450DW	450±1.5	4	2	±10	±20	40	1500
LT450EW	450±1.5	6	2	±7.5	±15	40	1500
LT450FW	450±1.5	6	2	±6	±12.5	40	2000
LT450GW	450±1.5	6	2	±4.5	±10	40	2000
LT450HW	450±1.0	6	2	±3	±9	40	2000
LT450IW	450±1.0	6	2	±2	±7.5	40	2000
LT450HTW	450±1.0	6	2	±3	±9	60	2000

Dimensions [mm]

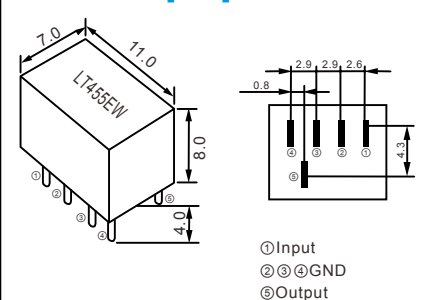

Test Circuit

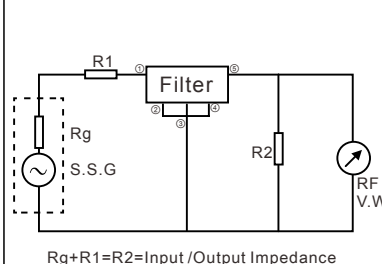

Characteristics

